



360 west aspen avenue
salt lake city, utah 84101
801 532 4422

UNLESS A PROFESSIONAL SEAL WITH SIGNATURE AND DATE IS AFFIXED, THIS DOCUMENT IS PRELIMINARY AND IS NOT INTENDED FOR CONSTRUCTION, RECORDING PURPOSES, OR IMPLEMENTATION.



Engineered Systems Associates
ESA JOB NUMBER 20048

THE DESIGNS SHOWN AND DESCRIBED HEREIN INCLUDING ALL TECHNICAL DRAWINGS, GRAPHIC REPRESENTATIONS & MODELS THEREOF, ARE PROPRIETARY & CAN NOT BE COPIED, DUPLICATED, OR COMMERCIALLY EXPLOITED IN WHOLE OR IN PART WITHOUT THE SOLE AND EXPRESS WRITTEN PERMISSION FROM METHOD STUDIO INC.

project:
BYUI Engineering Technology Center (ETC)

project#: 20.0220
byuidaho project#: 12005
date: oct. 27, 2020

revisions:

title:
MECHANICAL SECTIONS

sheet:
M201
100% construction documents

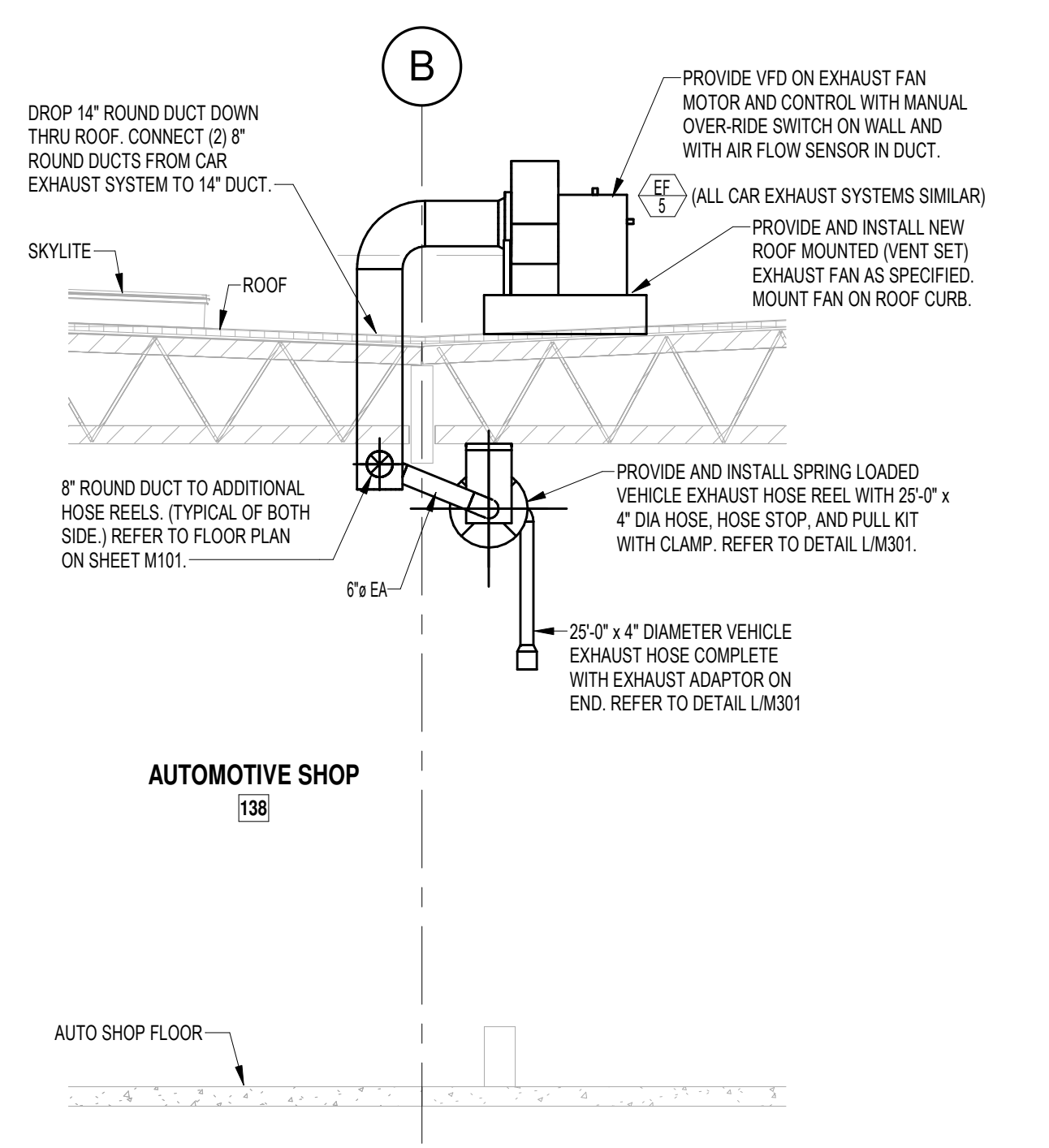

1 MECHANICAL SECTION 1
M201 1/4" = 1'-0"

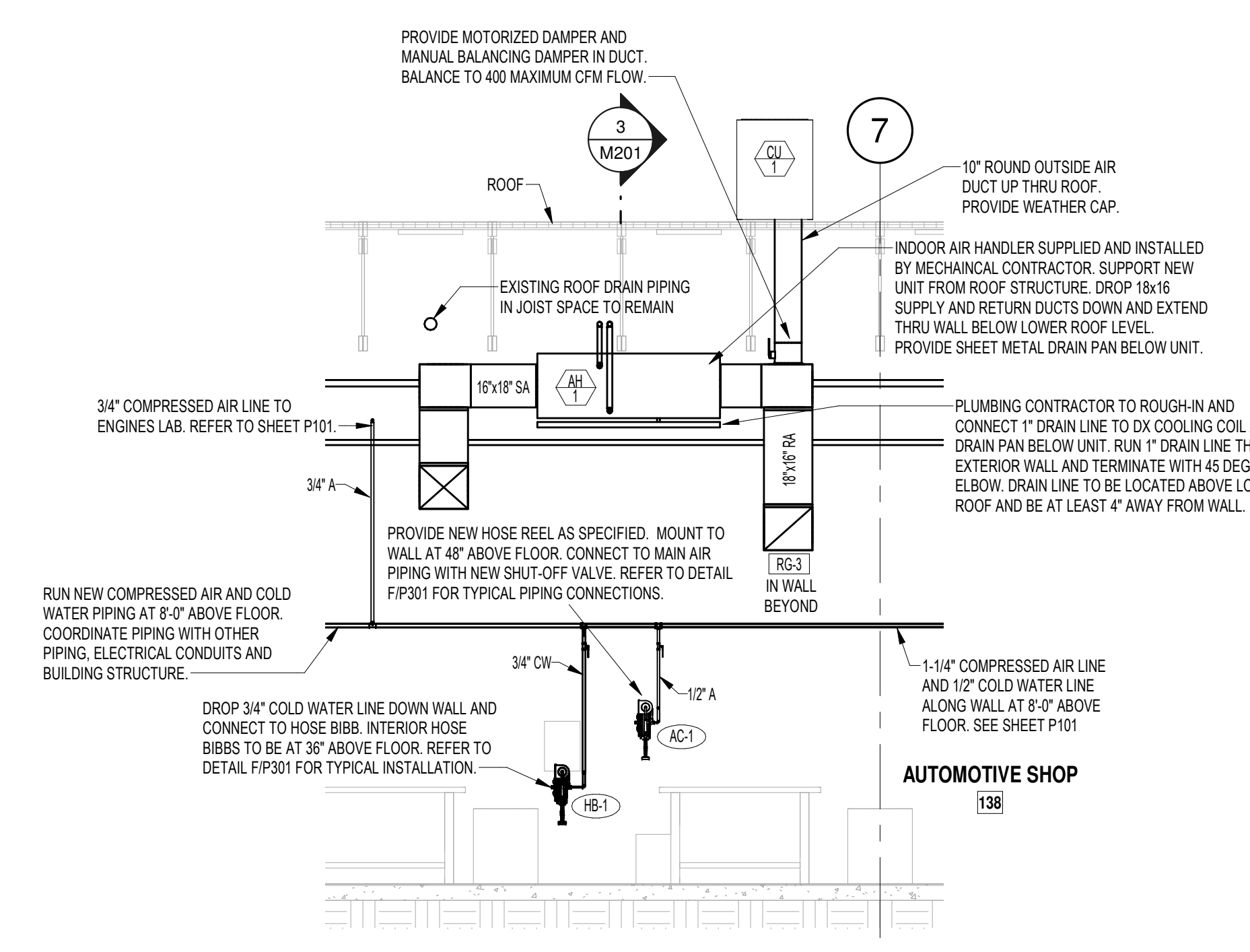

2 MECHANICAL SECTION 2
M201 1/4" = 1'-0"

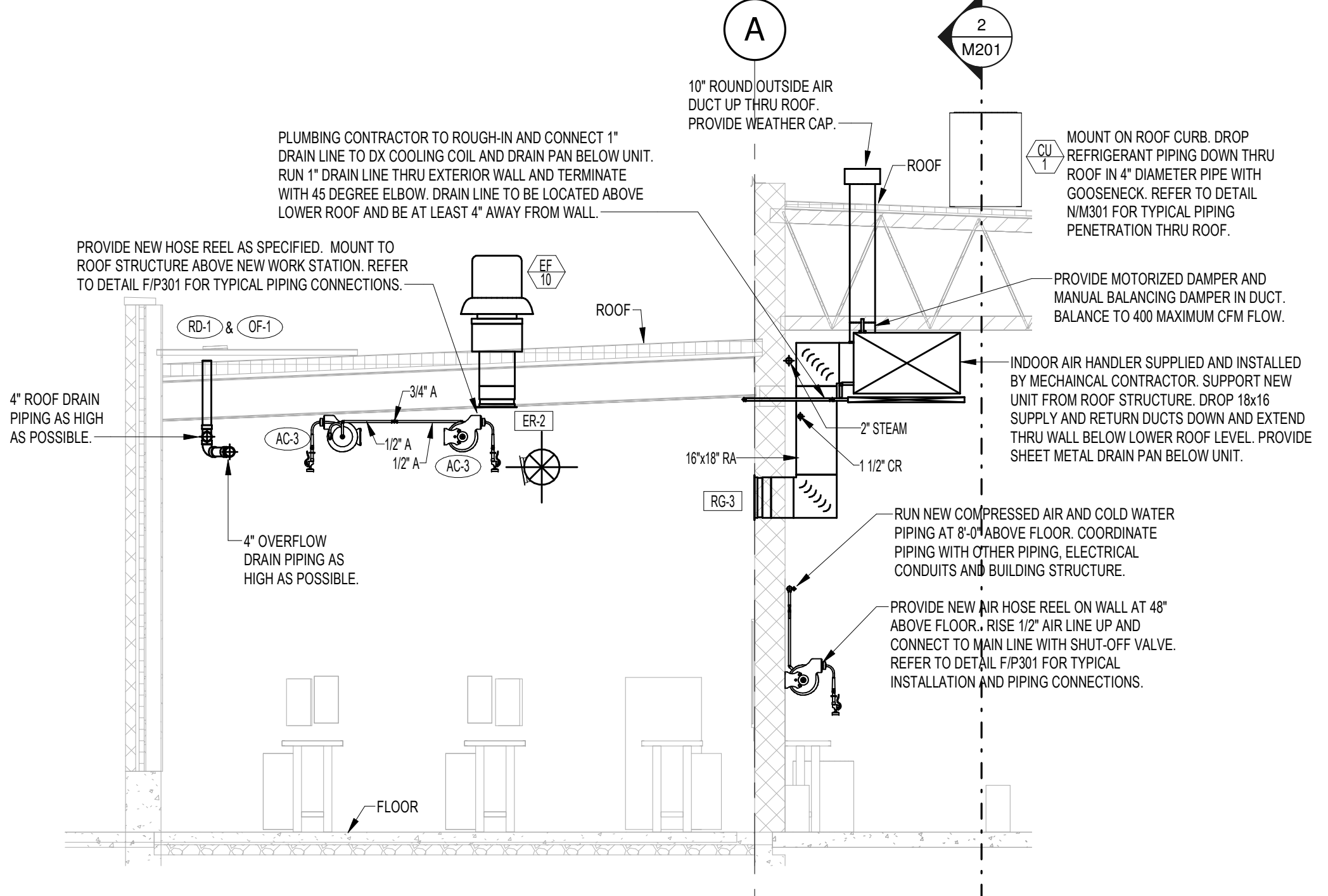

3 MECHANICAL SECTION 3
M201 1/4" = 1'-0"

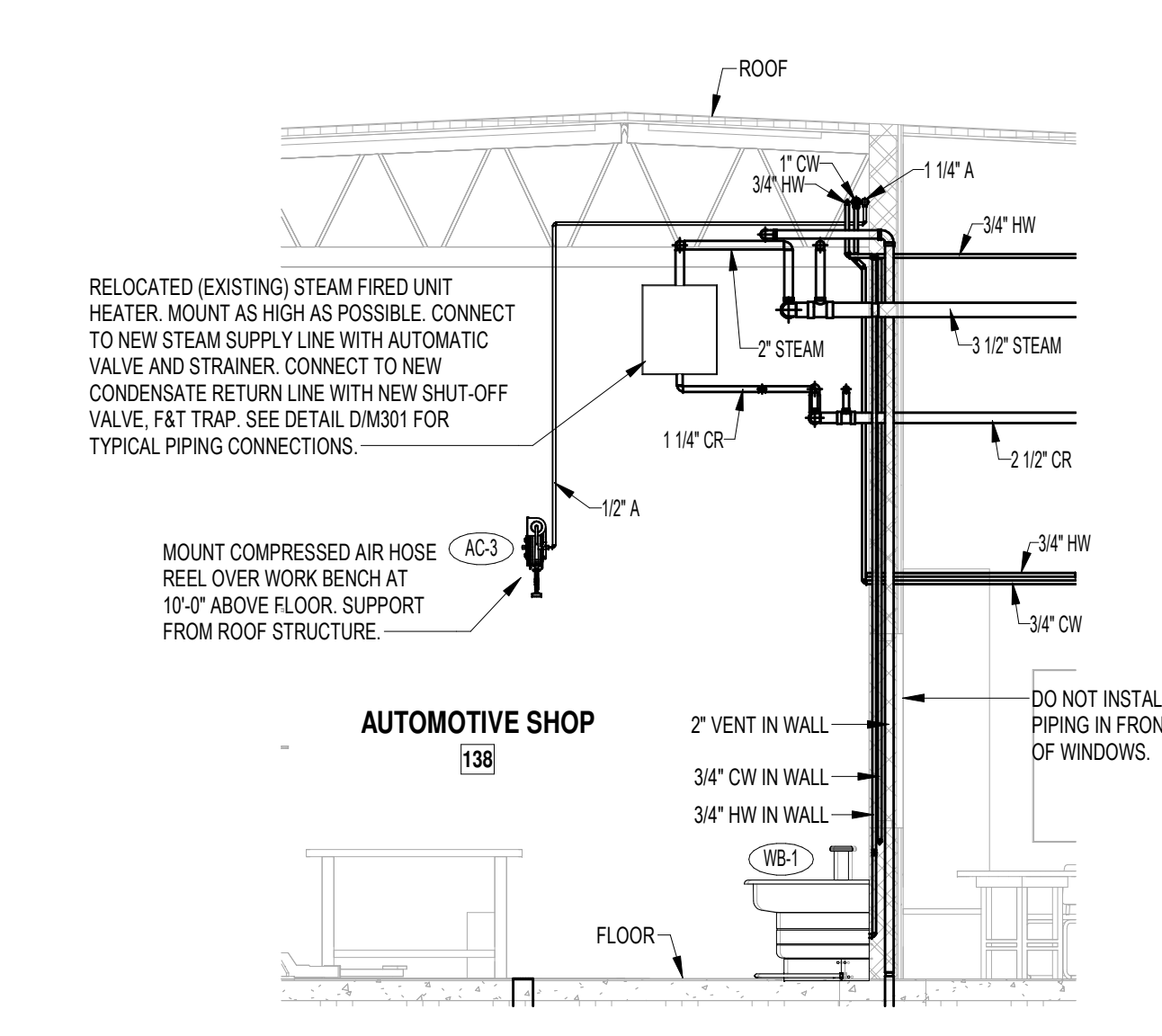

4 MECHANICAL SECTION 4
M201 1/4" = 1'-0"

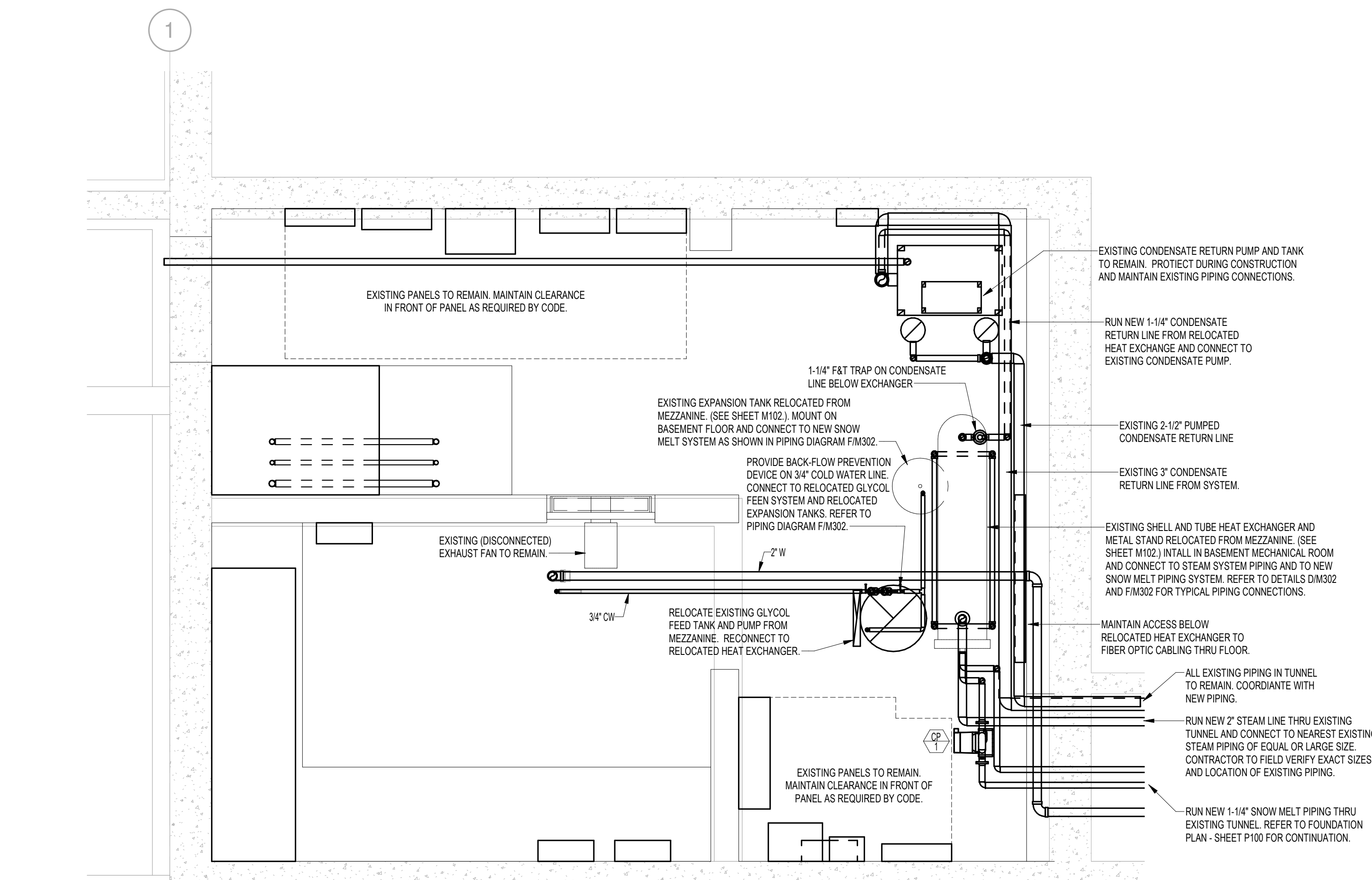

5 BASEMENT MECHANICAL ROOM
M201 1/2" = 1'-0"